

GUIDELINES FOR WORKSHOP PRACTICE

Surface Treatment of
PLEXIGLAS®

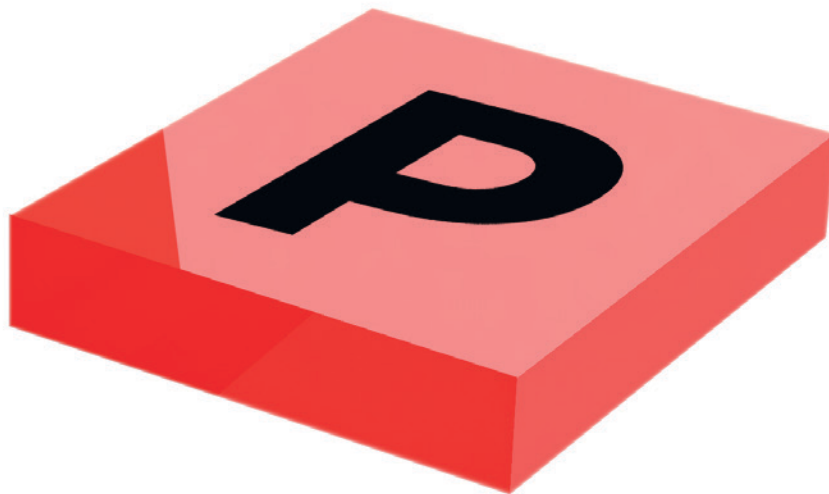

Inhalt

1. General Remarks.....	3
1.1 Physical Forms.....	3
1.2 Properties and Conditions.....	3
1.3 Masking Film.....	4
1.4 Scoring and Marking.....	4
1.5 Subsequent Surface Protection.....	4
2. Avoidance of Static Discharges	4
3. Screen Printing.....	5
4. Coating.....	6
4.1 Spray Painting.....	6
4.2 Dip Coating.....	6
4.3 Curtain Coating.....	6
4.4 Roller Coating.....	8
5. Matting	8
5.1 Mechanical Matting.....	8
5.2 Matting by Thermoforming.....	9
5.3 Chemical Matting.....	9
6. Stamping and Inscription	10
7. Surface Dyeing	11
8. Transfer Printing.....	12
9. Laminating	12
10. Metallizing.....	13
10.1 Sputtering in a High Vacuum.....	13
10.2 Wet Vaporizing, Electroplating, Metal Spraying.....	13
11. Abrasion-Resistant Coating.....	13
12. Water-Dispersing Coating.....	14
13. Cleaning and Care	15
13.1 Cleaning.....	15
13.2 High-Pressure Cleaning.....	15
13.3 Removal of Spray Paints and Posters.....	15

Notes:

In addition to this publication, there are similar Guidelines for Workshop Practice for professional PLEXIGLAS® fabricators on:

Machining PLEXIGLAS®
(Kenn-Nr. 311-1)

Forming PLEXIGLAS®
(Kenn-Nr. 311-2)

Joining PLEXIGLAS®
(Kenn-Nr. 311-3)

You can find valuable do-it-yourself hints on PLEXIGLAS® in:

Fabricating Tips for PLEXIGLAS®
(Kenn-Nr. 311-5)

Special leaflets are available on the properties and fabricating behavior as well as the applications of several of our products, for example

- multi-skin and corrugated sheets
- glazing with solid sheets
- noise barriers
- signage and lighting.

These can be obtained from your local authorized distributor of PLEXIGLAS®.

When using our products, please observe

- local building codes and emissions laws
- applicable standards
- product liability imposed by law
- the guidelines of employers' liability insurance associations.

1. General Remarks

PLEXIGLAS®, the acrylic (polymethyl methacrylate, PMMA) manufactured by us, can be subjected to various kinds of surface treatment during fabrication. This is because of the favorable properties of this plastic, e.g. its perfectly smooth surface. Surface treatment normally adds value to the finished article and opens up applications for PLEXIGLAS® GS and PLEXIGLAS® XT® that the untreated base material would be unable to satisfy. Treatment ranges from decorative screen printing to more sophisticated techniques such as sputtering in a high vacuum.

Unlike some other plastics, the surface treatment of PLEXIGLAS® poses very few problems.

PLEXIGLAS® **GS** is produced by casting, PLEXIGLAS® **XT** by extrusion. Both types of material can be surface-treated in nearly the same manner. This also applies to PLEXIGLAS® products for specific applications, such as **SOUNDSTOP** (for transparent noise barriers), or grades with special surfaces. These can have an abrasion-resistant or mirror coating, or special surfaces such as **SATINICE** (matte), **HEATSTOP** (reflecting solar heat), or **NO DROP** (water dispersing).

Differences in machining behavior are noted in the respective section.

It is the aim of this brochure to help you achieve optimal forming results. If you have any questions about our information or the practical work based on it, contact your local authorized distributor or our **Technical Service** department. We ourselves will be grateful for any suggestions based on your experience in the field.

Apart from the techniques discussed here, which are to be performed by the fabricators, we ourselves offer material with upgraded surfaces, e.g.

- PLEXIGLAS® and EUROPLEX® PC film with abrasion-resistant coatings,
- PLEXIGLAS® multi-skin sheets with water-dispersing coatings,

- sheets with matte, satin surface on one side, as well as sheets, tubes and rods with two matte satin surfaces (PLEXIGLAS® Satinice, PLEXIGLAS® Satin Ice, PLEXIGLAS® Crystal Ice).

Combinations of these techniques are sometimes also possible.

1.1 Physical Forms

PLEXIGLAS® GS is manufactured in the form of solid sheets, blocks, tubes and rods with smooth or matte, satin surfaces (**PLEXIGLAS® Satinice**).

PLEXIGLAS® XT is available in standard and impact-modified grades (**PLEXIGLAS® Resist**) as smooth, textured or matte (**PLEXIGLAS® Satinice**) solid sheet, corrugated and multi-skin sheet, mirrors, tubes and rods as well as (**EUROPLEX®**).

Colored PLEXIGLAS® grades are normally homogeneously colored.

Whether in standard or special sizes, all material packaged on pallets is labeled with information for correct storage and in-house transport. Generally speaking, PLEXIGLAS® is best stored indoors. All our sheets are masked with polyethylene film, which can be disposed of without any problem. In the case of outdoor storage, effective additional protection is required.

1.2 Properties and Conditions

The material behavior of PLEXIGLAS® permits many different types of surface treatment that are not always possible with other plastics. Owing to its high resistance to chemicals, it is very versatile in use and, at the same time, enables partial solvent action in a way that favors a wide variety of coating techniques.

Our leaflets entitled 'Chemical Resistance of PLEXIGLAS®' (Ref. No. 211-2) and 'Resistance to Stress Cracking and Chemical Influences' (Ref. No. 211-4) provide information on the general behavior of PLEXIGLAS® GS and XT towards chemicals.

Similarly to bonding, most methods of surface treatment require items with **no or only moderate internal stress** as a result of production technique or machining. High stress levels must be eliminated by annealing (see Guidelines for Workshop Practice, 'Machining', chapter 8, or 'Joining', chapter 2.5).

Prior to surface treatment, the items usually need to be **cleaned**. This can be done by blowing down with ionized air or by rinsing with warm water to which some dishwashing liquid has been added. For subsequent drying, an absorbent, non-linting cloth, e.g. glovelining fabric, should be used. Wiping down with ANTISTATIC PLASTICS CLEANER may be useful, but this has to be established from case to case. Certain types of surface treatment call for plastics surfaces that are immaculately clean. This cannot be guaranteed when antistatic cleaners have been used. Suitable products for cleaning and degreasing prior to surface treatment are THINNER AND CLEANER 30/ACRIFIX® TC0030, petroleum ether as well as uncolored absorbent paper or cloth (washed glove-lining fabric) soaked with isopropyl alcohol. All agents mentioned are suitable for **short-term use** on PLEXIGLAS® GS and PLEXIGLAS® XT.

For certain types of surface treatment it makes sense to order the material from your local authorized distributor with a corresponding note, so that he can perhaps select a special grade which makes the desired kind of surface treatment particularly easy (see chapter 11, Abrasion-Resistant Coating').

1.3 Masking Film

Depending on material grade and thickness, the surfaces of our sheets are masked with environmentally friendly self-adhesive or cling film made from polyethylene. Normally, the surface masking should remain on the sheet until it is in its final place.

If the film must be removed before surface treatment: hold the sheet firmly down on one side and strip off the film with one quick movement of the hand.

When sheets are exposed to the weather, the masking films must be removed within four weeks, regardless of their adhesive properties, since polyethylene may become brittle after this period of time or adhere even more strongly. In either case the films can no longer be

properly removed, and the sheets are likely to be damaged.

1.4 Scoring and Marking

The environmentally friendly PE masking film is intended to protect PLEXIGLAS® sheets during transport and storage. This protective film should remain on the sheet during all machining operations, and is best left on until the finished part is in its final place.

Marking out of drill holes, contours or edges to be cut off is therefore done on the masking film. If the latter has already been removed, use special pencils (e.g. soft lead or grease pencils) for marking out directly on the sheet surface.

Scribers or prick punches should not be used unless it is ensured that the notches they cause are eliminated

in a subsequent operation. Otherwise, all materials mentioned – even impact-modified PLEXIGLAS® Resist – may crack or break under load.

1.5 Subsequent Surface Protection

When machined sheets, semifinished or finished parts – but also installed elements – made of PLEXIGLAS® need to be protected against soiling, chemical or other influences during further treatment or storage – e.g. for renovation purposes – the following measures can be recommended:

- coatings applied in liquid form; which can later be stripped off as films (such as 30 % aqueous solutions of PVAL) or protective films
- compatible adhesive crêpe tapes adhesive polyethylene films or polyethylene bags, which are then closed or heat-sealed.

2. Avoidance of Static Charges

Owing to their excellent insulating properties, most plastics, including PLEXIGLAS® GS and XT, show high surface and volume resistivity. As a result, they may become statically charged with the associated negative effects of dust attraction and (rarely) flashover. Static charges may build up due to:

- mechanical friction in contact with solid objects, cloths or polishing agents;
- friction produced by dry air currents, for example;
- removal of the masking film from the sheet.

Static charging upon removal of the masking film, for example, causes an electron surplus on one sheet surface and electron deficiency on the other. The charge may, however, vary on the same surface of a sheet or finished item. In the case of electrically insulating plastics, this difference will not balance itself. The charges – negative or positive – are up to several

hundred volts high and cannot be dissipated unless the surface comes into contact with another conductive or reversely charged material, when a flashover occurs.

The ability to become statically charged can be eliminated by applying surface layers that contain moisture-binding electrolytes or by adding electrolytes to the polymer formulation. The latter is not recommended for acrylics, though, since the doses required to produce an antistatic effect change the properties of these polymers, e.g. their optical appearance, so very noticeably that the final product becomes unsuitable for most applications.

As mentioned further above, it is common practice to treat the **surfaces** of PLEXIGLAS® GS and XT with antistatic substances as a preventive measure, or else to eliminate the charges once they have built up. Rinsing with water is the simplest form of external antistatic treatment.

Very often, however, it is better to use an antistatic cleaner (see ,13 Cleaning and Care').

The effectiveness of antistatic treatment is inversely proportional to the volatility of the active substances contained in the product: the lower the friction, the higher the atmospheric humidity, the lower the room temperature and the less dust there is around, the longer the antistatic effect will last.

Another very economical method is blowing the sheet or parts of it down with ionized air. The effect, however, is of fairly short duration, e.g. just long enough for the next work step to be performed.

3. Screen Printing

Screen printing is the best-known method for decorating large runs of PLEXIGLAS®. It permits reproduction of the most intricate details of complex motifs.

Screen-printed sheets can be thermoformed at the appropriate temperatures without damaging the print. That enables raised patterns or three-dimensional moldings to be produced from screen-printed flat sheets.

Most important in this context is the heating method: Whereas oven heating normally ensures a uniform degree of stretching, IR radiators involve the risk of irregular heating of multi-colored parts, thereby disturbing the thermoforming process.

In order to avoid distortion of the printed pattern, certain areas may be covered while heating the remainder of the sheet with IR radiators.

Screen printing may be performed by hand or screen printing machine for larger runs (see Fig. 1).

The sheet to be printed is placed on a table, fastened with clamps or by means of a suction plate. A squeegee is used to press the ink through a porous screen made of fabric tightly stretched in a frame and a mesh stencil with the photochemically applied negative of the printing pattern. The distance between the underside of the stencil and the sheet surface must be such that the image area touches the screen only at those points across which the squeegee is drawn. This distance is usually between 5 and 10 mm, depending on the size of the stencil.

The **mesh** stencil consists of a frame holding a stretched polyamide or polyester fabric with 80 to 140 threads per cm and the stencil proper. For coarse substrates or rich multi-color printing a coarse mesh is used, and a fine mesh for sharp contours and intricate details.

The **stencil** proper is normally prepared photochemically: the mesh is co-

vered with a light-sensitive layer and exposed to light through a positive. The exposed areas cure, the unexposed ones can be washed out.

For multi-color printing, one mesh stencil is needed for each color. Lay marks at their edges ensure that the differently colored areas are clearly defined. Before the next printing step is performed, the previously applied ink has to be sufficiently dry.

Subsequent spray coating with a clear protective varnish improves the weather resistance of the print. Alternatively, the print may be applied to the back of cut-to-size sections of transparent, UV-absorbing PLEXIGLAS® grades, where it is protected against climatic influences and mechanical stress (see also Chapter 4.1).

After the printing process, stencil and squeegee should be carefully cleaned with cleaning agents or paint thinners recommended by the ink manufacturers. Depending on the type of ink used, the printed items are left to dry at room temperature or above (approx. 60 °C).

Screen-printed parts that are to be thermoformed require a stencil that allows for the distortion caused by forming. To this end, the desired

contours are drawn on a formed part, preferably made of PLEXIGLAS® **GS**, which is then heated and restored to its original flat state. The distorted image corresponds to the stencil to be made (distortion printing).

For screen-printing PLEXIGLAS®, use inks that do not cause stress cracking in acrylics, but adhere well enough for the application. The instructions of the ink manufacturers should be observed, as they offer different products for different types of plastics.

The solvents contained in the inks are likely to have an adverse influence on the plastics surface. Therefore it may be advisable in some cases to anneal the parts prior to screen printing (see Guidelines for Workshop Practice, 'Machining', chapter 8, or 'Joining', chapter 2.5).

If screen-printed parts are to be area-bonded with polymerization adhesives such as ACRIFIX® 190/2R0190, for example, special crosslinked color lakes are to be used that withstand the solvents contained in this adhesive. Area bonds are described in our Guidelines for Workshop Practice 'Joining', chapter 2.7 Bonding Techniques.

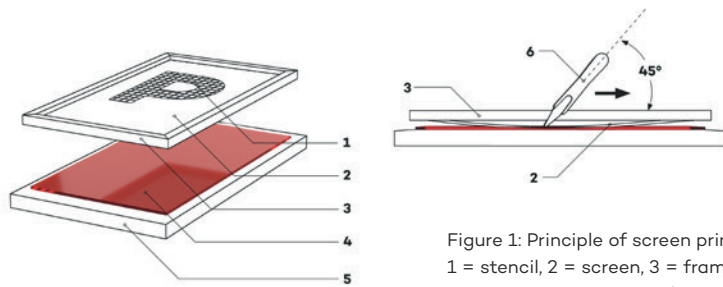

Figure 1: Principle of screen printing
1 = stencil, 2 = screen, 3 = frame,
4 = PLEXIGLAS®, 5 = worktop, 6 = squeegee

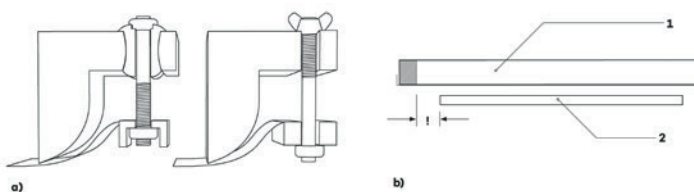

Figure 2: Screen printing frame
a = Sections of different frames,
b = Size of screen printing frame (1)
as compared with surface to be printed (2)

4. Color Coating

Coating is the second most widely used method of surface treatment and many of the details to be borne in mind have already been mentioned in connection with screen printing. Thus, the workpieces to be coated need to be carefully cleaned and treated with an antistatic where necessary (see chapter 1.2). Annealing to relieve internal stress may also be required (see Guidelines for Workshop Practice ‚Machining‘, chapter 8, or ‚Joining‘, chapter 2.5).

4.1 Spray Painting

Spray painting is equally suitable for individual items and large runs. The paint loss is usually higher than in screen printing, but can be limited by the choice of nozzle and spraying technique. The spray gun atomizes the paint and deposits it on the surface to be painted (See Figs. 3 and 4). Using stencils or masking lacquers, it is possible to paint certain areas only or to apply symbols and lettering.

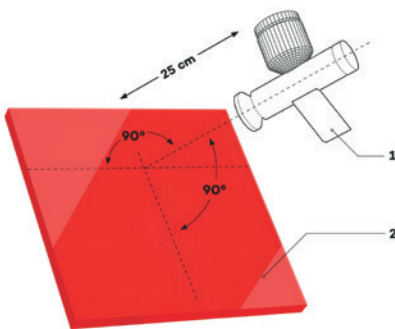

Figure 3:
Position of spray gun in relation to workpiece
1 = spray gun, 2 = PLEXIGLAS®

The walls and floors of the **workroom** must be solvent-resistant and easy to clean. The spray booth (see Fig. 5) should be provided with a water curtain and an extractor that at least complies with environmental regulations.

Explosion-proof electrical installations and luminaires are a must. Otherwise the guidelines of the employers' liability insurance association are to be observed.

Constant temperatures between 18 and 25 °C are an essential prerequisite for maintaining the viscosity of the coating systems at the same level for all processes and for avoiding condensate formation. While the relative humidity should not be higher than 60 %, an adequate supply of fresh air is to be ensured.

The paint and the clean workpiece should be taken to the workroom in good time so as to acquire the same temperature before painting is started.

Just as there are special inks for screen printing, there are special paints for spray painting. The major requirement is that they adhere well to PLEXIGLAS® GS and XT, are easy to process, compatible with PMMA, weather-resistant and formable along with the substrate.

Areas not to be painted or to be painted in different colors are covered with **stencils, adhesive film or removable masking lacquers**. The latter are applied by brush or spray gun. When they are dry, the contours are marked on them, or the film, by means of a fine scoring knife, and the areas to be painted are laid open. Please bear in mind that scoring may have a notch effect. Stencils must be firmly secured and should be cleaned at regular intervals. Once painting and drying are completed, remove the remaining bits of lacquer or film.

In some cases, the masking film applied to our sheets for protection during transport may replace the stencil or adhesive film, provided it still adheres well enough. There are two alternative ways to **build up a paint coat**:

In the majority of cases, paint coats are applied to **translucent or opaque colored** sheets of PLEXIGLAS®. The coated side is normally the one exposed to the weather and mechanical stress. A clear varnish offers additional protection.

When treating **clear-transparent** PLEXIGLAS® sheets – the second option – the coating can be applied on the back of the sheet for improved weather resistance. This requires an additional paint coat, e.g. to provide logos or symbols with a (colored) background or base coat (see Fig. 7).

4.2 Dip Coating

Dip coating is often the method of choice for priming or for applying protective coatings. Thus, PLEXIGLAS® can be coated with masking lacquers prior to spray painting or metallized surfaces can be protected with clear-transparent or transparent colored coatings. For dip coating, the workpiece is completely or partially immersed in the paint bath. This enables all-round coating in one step (see Fig. 8).

The layer thickness usually varies according to the consistency of the coating system or its solids content. Moreover, the jig required for all-round coating causes some flaws. In order to increase the layer thickness it may be necessary to dip the workpiece several times and let it dry in between.

Drying is performed with IR radiators or by means of warm air. It should be as forceful as possible in order to prevent the paint from running down too quickly on vertical surfaces, thereby forming so-called sags.

4.3 Flow Coating

Flow coating is best suited for coating large, even surfaces of PLEXIGLAS®. Very uniform layer thicknesses are achieved by this process, which is necessary to get a uniform color impression with large, transparent colored or translucent items. Flow coating is thus mainly used for applying base and top coats to illuminated advertising signs and for the manufacture of projection screens.

The **flow coating machines** available in the market operate more or less by the same principle (see Fig. 9). The differences are mainly in design and in the accessory equipment offered.

Because of the high coating speeds, this technique is particularly suitable for large production runs.

Generally speaking, the **coating systems** are the same as for spray painting, but the required viscosities are normally different. It is important to choose systems that are compatible with PLEXIGLAS® and satisfy the special requirements of the envisaged application.

Processing and post-treatment are to be performed according to the manufacturers' recommendations. The general advice given in the previous chapters also applies here.

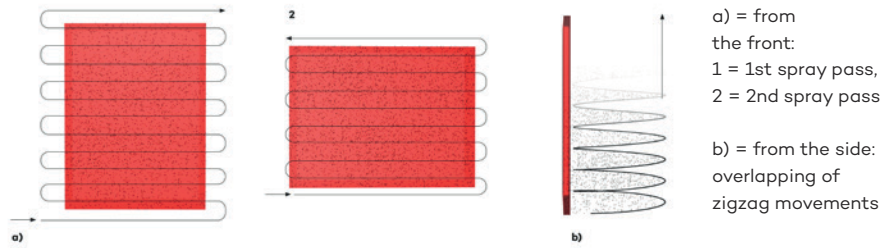

Figure 4: Guiding the spray gun in crisscross fashion

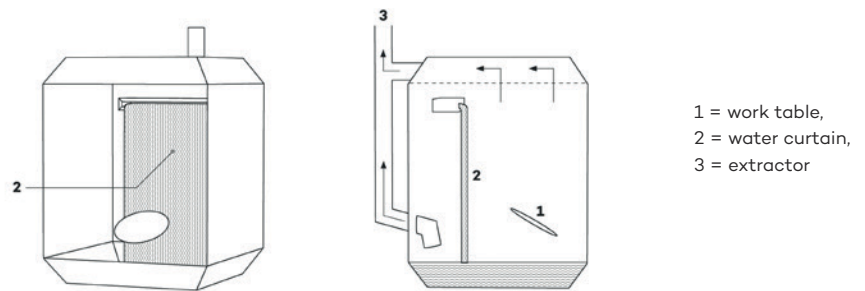

Figure 5: Schematic of a spray booth

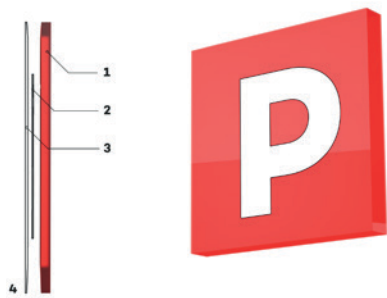
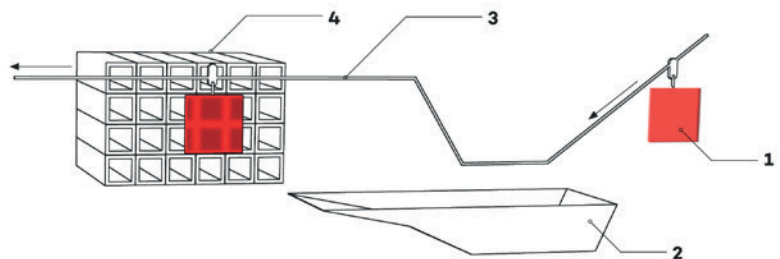

Figure 6:
Buildup of a paint coat on the front
1 = PLEXIGLAS®, e.g. homogeneously colored in yellow
2 = symbol (K), e.g. red paint
3 = clear protective varnish
4 = weather side



1 = PLEXIGLAS® part, 2 = paint trough,
3 = conveyor unit, 4 = drying section

Figure 8: Schematic of a semi-automatic dip coating line

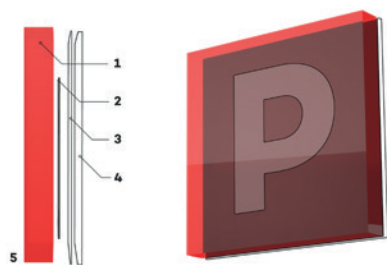

Figure 7:
Buildup of a paint coat on the back
1 = PLEXIGLAS®, Clear
2 = symbol (K), e.g. red paint
3 = base coat (background), e.g. yellow paint
4 = clear protective varnish
5 = weather side

1 = PLEXIGLAS® section,
2 = paint feeder,
3 = paint,
4 = adjustable gate,
5 = coating layer,
6 = overflow trough,
7 = conveyor belt,
8 = from pump,
9 = to pump

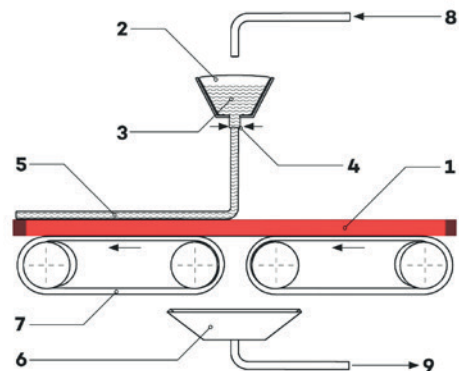

Figure 9: Principle of flow coating

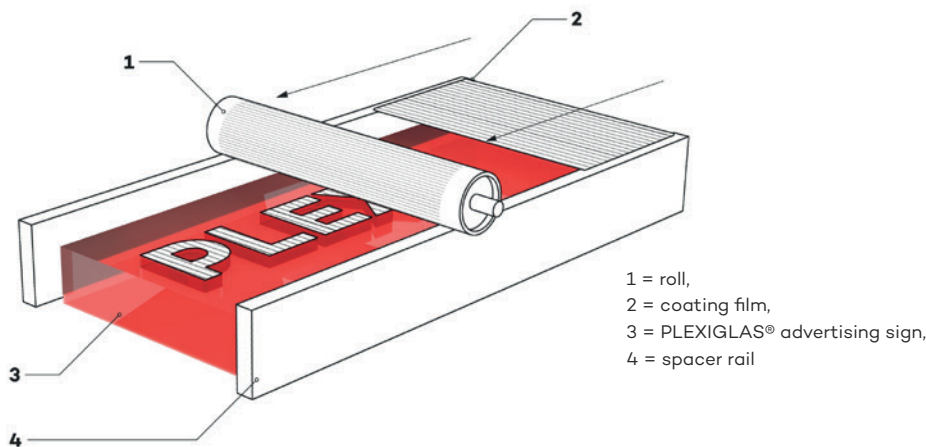

Figure 10:
Principle of roller coating

4.4 Roller Coating

Roller coating is widely used for workpieces made of PLEXIGLAS® with raised or sunken designs, e.g. advertising signs with logos or emblems. It is also suitable for applying opaque base coats or clear protective coatings, for the manufacture of liquid film maskings and lettering applied by template. Small production runs can be roller-coated manually with satisfactory results. Before starting the pro-

cess, the workpiece must be cleaned, degreased and dried.

For roller coating, the paint is first spread evenly on a smooth and level surface and is then taken up by the roller. The paint-soaked or moistened roller - guided by spacer rails on both sides - is carefully passed over the workpiece. In the case of raised patterns (reliefs) this ensures that only the projecting surfaces are coated (see Fig. 10).

The roller has an elastic, wettable cover - usually made of finegrained rubber - whose hardness (approx. Shore A 45) should be adjusted to that of the surfaces to be coated. The more clearly defined the contours and the smoother the surfaces, the harder the rubber may be.

Important for perfect coating is the right viscosity of the paint and adequate drying time.

5. Matting

PLEXIGLAS® is available in a number of clear, white and colored grades with smooth, textured or matte surfaces. The latter family of grades, **PLEXIGLAS® Satinice**, offer highly attractive options all from one source to designers and fabricators: cast Satinice **SC** with one satin surface and **DC** with two satin surfaces, extruded PLEXIGLAS® Gallery **AR** with an antireflective effect on one side, and the PLEXIGLAS® Satin Ice grade with two matte surfaces and the highest light diffusion. Apart from sheet material, tubes are also available in PLEXIGLAS® Satin Ice. Since these grades offer a very uniform matte effect that is suitable for many applications, this range dispenses with processing costs for subsequent matting.

Subsequent matting of PLEXIGLAS® surfaces is, of course, also possible. Several **mechanical, thermal and chemical processes** are known that allow you to achieve any desired degree of matteness between high

gloss and textured. Mechanical treatment, in particular of dark-colored material, may produce a grayish tinge, which is least noticeable with white material.

5.1 Mechanical Matting

In **sandblasting**, a stream of - usually - quartz sand, corundum or aluminum oxide strikes the surfaces to be matted at high speed. The degree of abrasion or matting depends on the impact velocity as well as the particle size and shape of the material used.

Large areas are best treated by machine, since matting by hand is often irregular. Partial matting is also possible if the areas to remain glossy are covered with stencils or self-adhesive film.

While sandblasting produces good **matte effects**, the surfaces thus treated are **sensitive to touch**, i.e. may change in appearance as a result of fingerprints or dirt pickup.

Another feasible matting technique is **sanding** with emery paper or emery cloth. We recommend wet sanding in order to generate a minimum of stress within the sheet or formed article. The textures produced show the preferred direction of sanding. Since they are never perfectly regular, sanding is usually only performed on surfaces of minor importance or, on the contrary, where precisely this kind of texture is desired.

For further details on sanding, abrasives and grits to be used, see our Guidelines for Workshop Practice, 'Machining', chapter 7.1.

Matte surfaces can also be produced on PLEXIGLAS® by means of rotating **brushes**. Their bristles are made of steel or brass, or else of plastics such as polyamide fibers. Round brushes fitted with strips of emery cloth, so-called flap wheels, are also widely used.

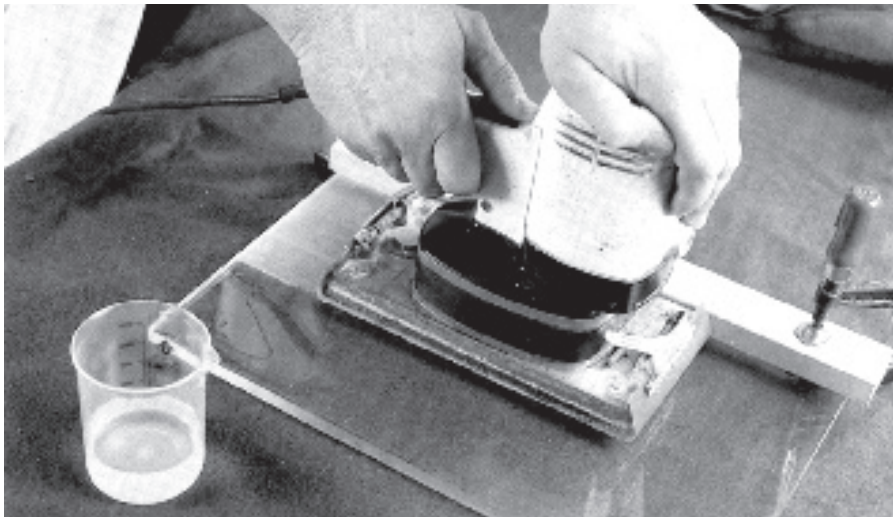

Figure 11: Mechanical matting with an orbital sander

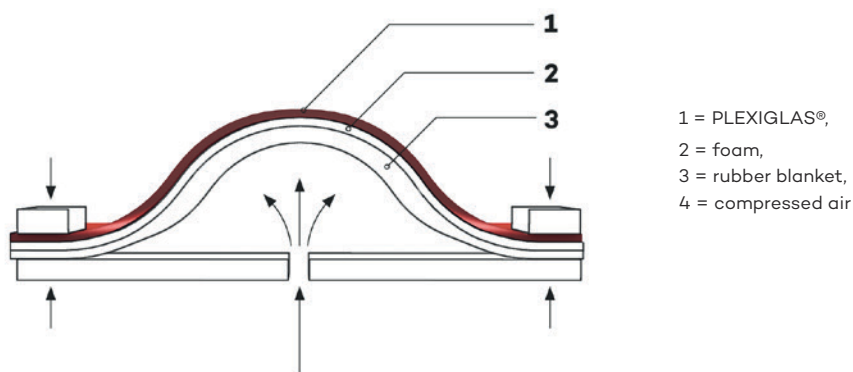

Figure 12: Schematic of blow molding of a light dome with matte interior surface

5.2 Matting by Thermoforming

PLEXIGLAS® XT and to a limited extent also PLEXIGLAS® GS can be matted by thermoforming. To this end, the sheets are heated to forming temperature and placed over molds with matte surfaces which are reproduced on the sheets.

The following techniques are possible (mentioned in order of increasing technical outlay):

- forming on soft foam, e.g. polyether or polyurethane;
- forming on ROHACELL® rigid foam,
- forming on dull material surfaces, e.g. sandpaper, textile fabrics, non-wovens, glassfiber mats, wood or matted plastics; (a PLEXIGLAS SATINICE® SC or DC surface can, for example, be reproduced on (briefly) thermoformed PLEXIGLAS® XT moldings).
- forming on metal surfaces, i.e. sandblasted, etched or ground surfaces of steel or aluminum.

If the above-mentioned materials are heated, or at least conditioned, this normally enhances the matte effect. Especially heatconducting materials such as aluminum and steel should therefore be heated to the thermoforming temperature of the material to be matted, i.e. to a minimum of 80 °C for PLEXIGLAS®.

PLEXIGLAS® can also be partially matted in this way, in which case a pattern, logo or part cut out of a sheet is placed on the mold.

Compared with mechanical matting, matting by thermoforming provides surfaces that are less sensitive to touch. Moreover, even free-blown items can be matted in this way (see Fig. 12), provided the degree of stretching is not too high.

5.3 Chemical Matting

Matting with chemical substances such as solvents and acids, which work on or attack acrylic surfaces, is

not recommended. The matte effect is mostly irregular, stress cracking may occur and handling in general involves certain risks.

Solvents should only be used for producing a **satin** finish after **sanding**. To this end, the surface is first treated with coarse-grit paper, by hand or on the belt sander and is then wiped down with a cloth (rolled into a ball) soaked in methylene chloride (dichloromethane).

Care must be taken to wipe in the direction of sanding. In the case of PLEXIGLAS® GS Black 811/9H01, for example, this produces an ebony sheen (see Fig. 13).

6. Stamping and Inscription

The techniques employed for inscribing plastics surfaces are so diverse and so well-known that they do not need to be described in further detail here. Only a brief presentation of the techniques relevant to PLEXIGLAS® is therefore given.

Apart from the most simple direct (usually manual) means of inscribing PLEXIGLAS® with **pencils** (see Chapter 1.4), the best-known indirect method is to apply **stickers** (labels etc.) to the material. These are normally printed or inscribed, or are left blank for subsequent information to be included on the PLEXIGLAS® part.



Figure 13: Chemical treatment of a previously sanded surface

Lettering and motifs are often applied to large runs of cut-to-size sheets and moldings with round or slightly spherical surfaces by **tampon printing**. The parts pass through the printing machine, where an elastic ball of textile or plastic material (tampon) picks up a pre-printed inscription from the printing unit and transfers it individually to the parts in question.

For large series of mainly flat parts (or endless films), **ink jet printing** offers the advantage of being able to change texts fairly quickly by means of digital programming. This technique is used less for decorative or advertising purposes, more for technical statements (see marking of PLEXIGLAS® grades on the protective masking film).

Laser printing operates in a similar way, but allows much more individual inscription via PC control and with resolutions up to the most minute

characters or motifs. Apart from special laser inscription units, the CO₂ lasers employed for cutting PLEXIGLAS® sheets can also be used for this purpose to a limited extent (and with reduced performance).

The advantages of this type of inscription similar to engraving are that it is rapid, abrasion-resistant and dispenses with paints or printing inks. However, it also means that no colored laser inscriptions are possible, only light/dark contrasts of the given grade of PLEXIGLAS®.

Photochemical etching offers a special kind of inscription or the transfer of photographic motifs to the surface of films rather than sheets of PLEXIGLAS®.

No further details of this copying technique for plastics films are given here because the processing instructions of the manufacturers of the required chemicals must be closely followed.

The embossing of PLEXIGLAS® means the impression of scripts, symbols etc. by means of a heated die. A distinction is made between **blind embossing** (hot stamping) and **color embossing**. Both techniques mainly serve for marking, lettering or decoration.

For **blind embossing**, the die is heated to forming temperature and pressed into the cool material. The shape of the die is reproduced in the workpiece as a sunken 'engraving.'

Stamping should not take too long in order to achieve the sharpest possi-

ble contours. Approx. 2 to 3 seconds at 150 °C are normally sufficient.

We recommend you to determine the required stamping time by preliminary tests under actual conditions and to look out for a possible notch effect.

The process can be performed manually with the aid of brass dies inserted in soldering irons (see Fig. 14), or else in a press. The die temperature should be adjustable and be controlled by temperature sensors, if necessary.

The principle of **color embossing** is the same as that of blind embossing, with the additional feature that the impressed symbols are lined with colored foil or metal leaf. The latter consists of a carrier and a paint or metal coat with adhesion promoter. Die heat and pressure cause the color to be transferred to the workpiece (see Fig. 15). The die temperature depends on the type of foil or leaf but is generally between 70 and 100 °C for PLEXIGLAS®. These rather low temperatures limit the penetration depth of the die.

For large runs, stamping presses with automatic roller feed are used. They consume a minimum of foil and operate at high speeds. Moreover, several colors can be produced at the same time.

To help fabricators to select the appropriate inscription method, the table in Figure 16 provides an overview of the pros and cons of the various techniques.

a) = manually performed stamping

1 = soldering iron shaft, hot;
2 = brass die with raised types;
3 = PLEXIGLAS®

b) = stamped relief inscription

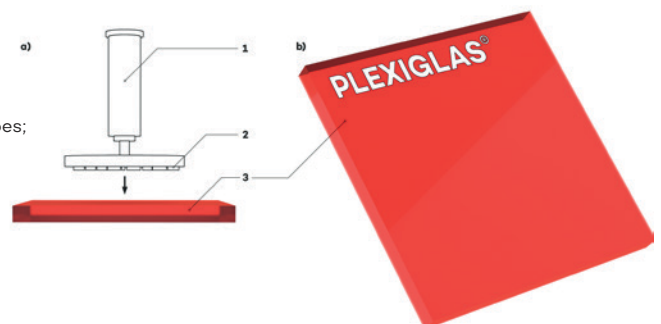

Figure 14: Hot stamping on PLEXIGLAS®

7. Surface Dyeing

Aqueous dye solutions are used for coloring the surfaces of – predominantly – transparent parts made of PLEXIGLAS® GS and XT. The swelling agents they contain, e.g. acetone, act at high temperatures. The process is suitable for small finished items of cut-to-size sheets of up to approx. 200 x 100 mm, which are immersed in the heated dye bath. Transparent colors show only limited resistance to light and weathering.

Machining and polishing of the items to be colored must be completed beforehand. They are placed in a warm aqueous bath to which a mild cleaning agent has been added, are thoroughly cleaned, degreased, rinsed with distilled water and dried. Annealing prior to dyeing is recommended (see our Guidelines for Workshop Practice ‘Machining’, chapter 8, or ‘Joining’, chapter 2.5).

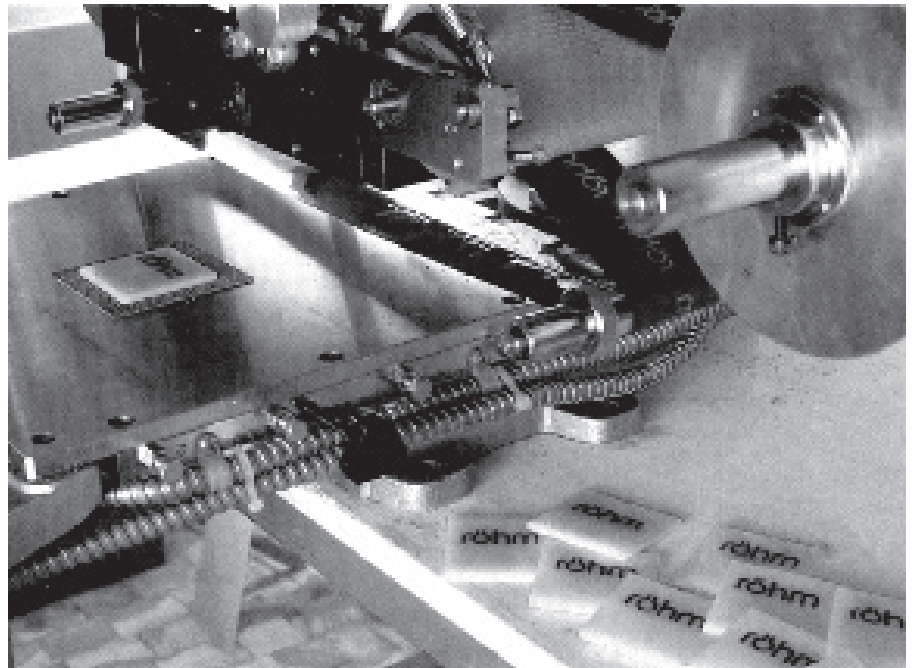

Figure 15: Color embossing of PLEXIGLAS®

Inscription					
	Laser	Inkjet	Tampon	Stamping	Label
Capital expenditure	•	+	-	+	+
Operating costs	+	•	•	+	+
Quality of inscription	+	+	+	+	+
Abrasion resistance	+	•	•	+	•
Permanent resistance	+	•	-	+	-
Micro-inscription	+	•	•	•	-
Inscription rate	+	+	•	•	+
Inscription of curved/matte surfaces	+	+	•	+	-
Inscription of “contaminated” surfaces	+	-	-	+	-
Accuracy of position	+	+	•	•	•
Reliability/availability of system	+	•	•	+	+
Insensitivity to touch	+	+	-	-	-
Integration into CIM environments	+	+	-	-	•
Freedom from paints/solvents	+	•	•	+	+
Flexibility (“batch size 1”)	+	+	•	•	•
Choice of printing colors	-	•	+	+	+

Special surface dyes and formulations are to be used, depending on the given technique.

Shades may vary from pale to rich, depending on how long the items are immersed in the dye solution. Uniform coloring is achieved by withdrawing the item slowly and carefully from a thoroughly stirred bath in which it was totally submerged.

Moreover, the temperature of the paint bath must be carefully monitored. Tests with smaller pieces are recommended. After the dyeing process, the workpiece is rinsed briefly with warm water, dried and placed in the oven for several hours at 70 °C to eliminate solvent and water residues.

Figure 16: Comparison of Inscription Techniques
 + = highly suitable • = suitable - = limited suitability or unsuitable
 (Source: A. Schulman GmbH, Kerpen, in PLASTVERARBEITER, 51st year, 2000, No. 12)

8. Transfer Printing

Transfer printing is the method by which a single- or multi-colored pattern is transferred from a carrier – usually transfer paper – to a flat item to be decorated. Printing occurs at high temperatures, so that the dyestuff migrates from the carrier to the item to be decorated and penetrates into it. The advantages of the process are the great variety of possible printing patterns and the extremely precise reproduction of even the finest details. This is particularly so if gravure-printed paper is used, but offset- and screen-printed paper also produces good results. Transfer printing is a fairly simple process but nevertheless requires some experience and technical know-how.

In the process, a sheet of PLEXIGLAS® GS or XT is placed in a heatable press. The printed paper – colored side facing the material – is placed on the sheet, carefully **avoiding any creases**. If necessary, a heatresistant release agent can be applied between the paper and the sheet to ensure neat separation after printing.

After placing the paper on the sheet, the press is closed and its heated platens are brought into close contact with the paper-covered sheet. The printed paper quickly reaches temperatures between 150 and 250 °C, the inks change from solid to gaseous and penetrate deep into the sheet to be printed. The penetration depth depends on the temperature, the type of ink used and the transfer period.

With PLEXIGLAS®, transfer may take up to 10 minutes. The pressure need not be very high, i.e. just high enough to ensure good contact between transfer paper and PLEXIGLAS® sheet without distorting the latter.

This printing technique does have a disadvantage, however: even if all due care is taken, residues of paper or release agent usually remain on the sheet surface or leave imprints.

This impairs the otherwise outstanding surface gloss of PLEXIGLAS®. The higher the transfer temperature and pressure and the longer the transfer

period, the more pronounced the loss of brilliance. The thickness tolerance of the sheet and the accuracy of the press also play a part in this context.

Against this background a process variant* was developed that permits printing of developable surfaces, i.e. surfaces that can be rolled out flat without distortion, such as cylinders or cones. Moreover, curved plastic surfaces of any desired configuration can be partially printed and, finally, distorted prints for subsequent thermoforming are also possible.

The newly developed “digital transfer printing” offers the PLEXIGLAS® fabricator a more economic access to this printing technique: quickly on PC generated designs can be printed directly onto transfer paper and thus transferred to PLEXIGLAS® parts in a cost-saving manner.

*) European Patent EP-B 1102 20 of Röhm GmbH

9. Laminating

The term laminating denotes the application of, mainly, films for decoration, lettering, identification, reinforcement (e.g. protection against splinters) or subsequent tinting (protection against sunlight) to workpieces of PLEXIGLAS® GS and XT.

Films can only be applied to flat, cylindrical or slightly curved surfaces. They can normally not be thermoformed together with PLEXIGLAS®.

When selecting the films, adhesive labels or decals, it must be ensured that they do not cause stress cracking in acrylics. This may be the result of plasticizers migrating from plastics films or attack by solvents contained in adhesives.

Since acrylics are gas-permeable, exhalation from the substrate may

cause partial detachment of the laminating film.

Where large areas are to be laminated durably and aesthetically, it is therefore recommended that the cut-to-size sheets or workpieces be dried for several hours in an airflow oven at 70 to 80 °C prior to laminating.

Pointwise or partial detachment of the film may, however, also be caused by dust particles from the air which settle between the sheet and the film.

Self-adhesive films should be rolled on without entrapping air bubbles or else applied to the sheet by means of a soft cloth. When laminating by hand, stripping off the masking paper and applying the film should be performed gradually, because otherwise the film would be very difficult to handle.

For laminating large areas, use a roller stack in order to avoid air entrapment and to achieve the necessary contact pressure for optically flawless application.

Laminating with non-adhesive film is slightly more difficult. Depending on the material used, special pretreatment may be required. Thus, for example, certain films are activated with water on their laminating surface and can then be applied by means of a blade.

Decals for labelling, lettering or decorating are often used in combination with screen printing or protective spray coating.et.

10. Metallizing

The smooth glossy surfaces of PLEXIGLAS® readily accept immaculate metal coats. Metallizing is above all used for providing optical devices with mirror coats or barrier layers, but also for decorative purposes. Since PLEXIGLAS® is electrically insulating, electrodeposition is normally not possible.

10.1 Sputtering in a High Vacuum

Sputtering requires some experience and should only be performed by specialists who also own the necessary equipment. Only the basic principles of this type of surface treatment will be discussed here.

As long as it is not finished workpieces that have to be metallized, PLEXIGLAS® XT Mirror sheets can be used instead.

In a special **vacuum chamber**, the metal to be applied – usually lowmelting aluminum – is heated to evaporation temperature. The condensing vapors cause the desired metal deposition on the PLEXIGLAS® parts.

The gloss and smoothness of the sputtered part depend on the original

surface quality of the workpiece. Therefore, care must be taken to choose injection molds with well-polished walls. Sheets or molded items must not be cracked or damaged. Depending on the intended use, the metal layer thickness is between 0.1 and 0.5 µm; in special cases up to 1 µm. A coherent metal coat forms at approx. 0.2 µm, below this value so-called semipermeable mirrors are obtained.

The essential prerequisite for successful sputtering is an **immaculately clean** substrate surface. This has to be borne in mind when ordering the sheets or when pretreating formed parts. In order to protect the vapor-deposited layer from mechanical damage, an additional coating is usually applied: clear-transparent on the front of the PLEXIGLAS® workpiece and possibly opaque on its back. Suitable application methods are spraying, dipping or flow coating.

Subsequent forming of sputtered sheets of PLEXIGLAS® or PLEXIGLAS® XT MIRROR by conventional techniques is impossible since the metal coat cracks when exposed to heat. The metallized parts can,

however, be curved cylindrically while cold, and to a limited extent even spherically if they are mounted in a round frame.

10.2 Wet Metallizing, Electroplating, Metal Spraying

Two methods are available for **wet metallizing**: chemical metallizing and silver-spray technique. Since chemical metallizing is not yet fully explored, it should not be used. The silver-spray technique can also be ignored, since it requires a considerable technical outlay and the adhesion of the metal coat is usually very poor.

Generally speaking, PLEXIGLAS® is suitable for **electroplating**. Apart from requiring extensive knowledge and experience, however, this technique is of minor importance for electrically insulating materials such as PMMA. It should only be performed by specialists.

Although **metal spraying** (also known as plasma or arc spraying) is performed in the plastics industry, it has only rarely been used for PLEXIGLAS®.

11. Abrasion-Resistant Coating

We offer abrasion resistant-coated PLEXIGLAS® and EUROPLEX® sheets and films in varying quantities, depending on demand. Specialized companies exist that have experience in providing sheets, blocks, tubes etc. as well as finished parts made from our products with abrasion-resistant coatings.

Optimum results can be guaranteed if the coating systems are specially adjusted to the particular product. This should be clarified in talks with the fabricator who will perform the abrasion-resistant coating process.

The parts to be coated should lend themselves easily to the process: changes in cross-section should be smooth; there should be no sharp contours, drill holes or recesses in order to avoid paint runs or paint buildup and other optical flaws.

Ejector lugs, sprues and manifolds on molded items may be used as means of suspension. This aspect should be taken into account when designing the mold or molding.

Suitable coating techniques are **dip, flow or spray coating**.

The high demands placed on surface quality are easiest to satisfy with flat or only slightly formed parts, (e.g. automobile side windows made from PLEXIGLAS RESIST®) that are cleaned automatically and then dip- or flowcoated.

The prerequisites for perfect surface coating are filtered coating systems, carefully cleaned substrates and performance of the coating process under **cleanroom** conditions in the appropriate climate. Such stringent requirements make sense if we consider that the final thickness of

the coating is approximately 8 µm, so that even minor impurities or dust particles will inevitably cause flaws.

It takes several hours of stoving at around 80 °C for the coatings to be fully **cured**. The higher the temperatures that can be adjusted (which naturally depends on the softening temperature of the substrate and the degree of shaping of moldings), the shorter the required curing times.

The **mechanical and thermal properties** of parts with abrasion-resistant coatings are more or less the same as those of the uncoated substrates. Given certain types of stress, however, the influence of the coating becomes very noticeable.

Coatings based on **polysiloxane** have a strain at break of 1.2 %. Strains beyond this value cause cracking in the coating. Abrupt flexural stress results in crack propagation into the substrate. Particular attention has to be paid to this effect if the layer

thickness exceeds 10 µm and the substrate is impact-modified. Coatings based on **melamine resin** with a strain at break of 7% do not show this effect.

Both abrasion-resistant coating systems improve the resistance to chemicals, particularly to short-term exposure to acids, alkalis and organic solvents.

Parts with a polysiloxane coating cannot be thermoformed, but cold curving is possible. The bending radius is 330 x sheet thickness. The surfaces can be printed under certain conditions, but coloring is not possible.

The flexible melamine top coat can be cold-curved with subsequent hot relaxation (application: visors for crash helmets). This coat can also be printed and embossed/cut.

In assessing abrasion resistance, a distinction is made between friction

and impact stress. What is determined is the increase in haze of the coated parts after treatment according to these test methods:

- (a) Taber Abraser test to ISO 9352 for frictional stress (e.g. during cleaning)
- (b) Falling Abrasive test to DIN 52348 for impact stress (e.g. sand entrained in head wind impinging on helmet visor).

The **machining behavior** of abrasion-resistant coated PLEXIGLAS® elements is slightly different to that of uncoated material. Whereas sawing, drilling, milling and edge polishing of sheets and formed parts are performed as usual, the surface with its hard crosslinked top coat cannot be polished; but this should not be necessary anyway. Nor can it be bonded using the normal adhesives for acrylics.

12. Water-Dispersing Coating

Water that settles or condenses on acrylics is likely to form droplets. Whereas this is no disadvantage for the majority of applications, in others a clear view must be preserved independently of the weather (e.g. transparent noise barriers made with PLEXIGLAS SOUNDSTOP®), or droplet formation on the interior surfaces of heat-insulating multi-skin sheets of PLEXIGLAS® is undesirable (e.g. under patio/conservatory roofs and greenhouses) as it reduces the light transmission and involves the risk of water dripping down and damaging the crops.

A **water-dispersing** coating, i.e. one which forms a water film, eliminates this drawback without affecting the

positive material properties. In fact, it enhances the transparency and speeds up drying.

As opposed to subsequent application of a water-dispersing agent, the **NO DROP** coating applied to PLEXIGLAS® products at our factory – or the all-round **Alltop** coating on some PLEXIGLAS® multi-skin sheets – offers the additional benefit of being weather-resistant and insoluble in water and therefore not having to be renewed from time to time.

The water-dispersing effect is achieved by increasing the solid-state surface tension over that of water. As a result, care must be taken in greenhouses that the **NO DROP**

surface of PLEXIGLAS® SP always faces inwards. In patio/conservatory roofs, on the other hand, it should face outwards (upwards). Rainwater then runs off as a film and the surface dries more quickly. Stains and water marks are largely avoided and the pleasant appearance and transparency are maintained. In order to safely prevent steaming up of crash helmet visors made of EUROPLEX® or PLEXIGLAS RESIST®, for example, an antifogging agent can be subsequently applied.

13. Cleaning and Care

Plastics normally become statically charged and attract dust as a result. Out of doors this is usually prevented by air and moisture, whereas in closed rooms this phenomenon is promoted by mechanical friction at the plastics surfaces, air currents and dry air.

For this reason, slightly soiled material should be treated immediately (heavily soiled material after thorough cleaning) with an antistatic agent, e.g. Burnus ANTISTATIC PLASTICS CLEANER, which should be sprayed on and distributed with a soft cloth without wiping the surface dry. The dust-repellent effect is then retained for a prolonged period of time.

Subsequent polishing of stressed surfaces (especially of PLEXIGLAS®) can be performed easily and effectively using the right cleaning and polishing agents. Windows and other exposed glazing areas may be cleaned by means of a highpressure spray-cleaning unit, possibly with some dishwashing liquid in the water.

13.1 Cleaning

Dirt can hardly cling to the smooth surfaces of PLEXIGLAS®. Dust is removed with water and some dishwashing liquid, using a soft, non-linting cloth or sponge. **Never wipe the sheets dry** and use only non-scouring agents for more intensive cleaning, e.g. ANTISTATIC PLASTICS CLEANER. A Vileda® Microclean cloth slightly dampened with water only has a good, largely streak-free cleaning effect. To remove more obstinate and especially greasy stains from PLEXIGLAS®, petroleum ether or benzine may be used.

'Post-treatment' of the smooth and glossy PLEXIGLAS® plastic surfaces is very simply done – even by hand – using polishing liquid or paste. These agents can also be applied by means of an orbital sander, provided it is covered with a soft cloth, or a lambswool polishing wheel.

Should there ever be scratches on a sheet of PLEXIGLAS®, these can be eliminated from the smooth surface without any problem. Treat the scratched area first with wet sandpaper of, say, grit 240, and then go over it with 400- to 600-grit paper. Finally polish the sheet with a soft cloth and ACRYLIC POLISHING PASTE or commercially available car polish, or else use a buffing wheel and polishing wax.

13.2 High-Pressure Cleaning

Large glazed areas or facades are often cleaned mechanically, using rotating brushes, squeegees and the like. No such methods are suitable for PLEXIGLAS®. Even if brushes are used with copious amounts of water, there is no way to exclude scratching of the sheet surfaces.

On the other hand, outward-facing PLEXIGLAS® surfaces can conveniently be cleaned with high-pressure/hot-water cleaning units. The recommended pressure is 50 to 100 bar and the water temperature should be between 50 and 80 °C. Via the integrated dosing unit, approx. 1 to 3 % of a moderately foaming cleaning concentrate should be added to the washwater, e.g. BURLANA® by Burnus.

Going over the surface once more with a squeegee is then neither necessary nor advisable. The sheets may, however, be wiped with a clean cloth to speed up air drying.

13.3 Removal of Graffiti and Posters

Spray paints on PLEXIGLAS® GS and XT can be removed with water-soluble brush cleaner.

To this end, cover the paint with a soaked cloth for up to 20 minutes, depending on type and layer thickness and then wash it off with plenty of water.

For PLEXIGLAS® parts with an abrasion-resistant polysiloxane coating, you may use VANDAL-EX. Pretreatment with paint-repellent substances is not recommended for acrylics.

Posters should be thoroughly soaked with water and some dishwashing agent for about 10 minutes, whereupon they can be removed with ease. We advise against pretreatment with poster-repellent products as these impair the appearance of the PLEXIGLAS® surface.



SUSTAINABILITY

The Sustainable Development Goals (SDG), adopted by the United Nations in 2016, all have one goal: By 2030, all inhabitants of planet Earth should be able to live in dignity.

To this end, the United Nations has formulated 17 goals to support global sustainability efforts. The SDGs are our compass in aligning our sustainability-strategy, creating innovations and identifying new business opportunities and take advantage of them.

Products and solutions from Röhms make a measurable contribution to achieving these goals. This is how we assume responsibility.



Röhms GmbH
Acrylic Products

Riedbahnstraße 70
64331 Weiterstadt
Germany

www.plexiglas.de
www.roehm.com

® = registered trademark

PLEXIGLAS, EUROPLEX und ACRIFIX are registered trademarks of Röhms GmbH, Darmstadt, Germany.

Certified to DIN EN ISO 9001 (Quality) and DIN EN ISO 14001 (Environment)

This information and all further technical advice is based on our present knowledge and experience. However, it implies no liability or other legal responsibility on our part, including with regard to existing third party intellectual property rights, especially patent rights. In particular, no warranty, whether express or implied, or guarantee of product properties in the legal sense is intended or implied. We reserve the right to make any changes according to technological progress or further developments. The customer is not released from the obligation to conduct careful inspection and testing of incoming goods. Performance of the product described herein should be verified by testing, which should be carried out only by qualified experts in the sole responsibility of a customer. Reference to trade names used by other companies is neither a recommendation, nor does it imply that similar products could not be used.