

PLEXIGLAS®
for Industry and Safety

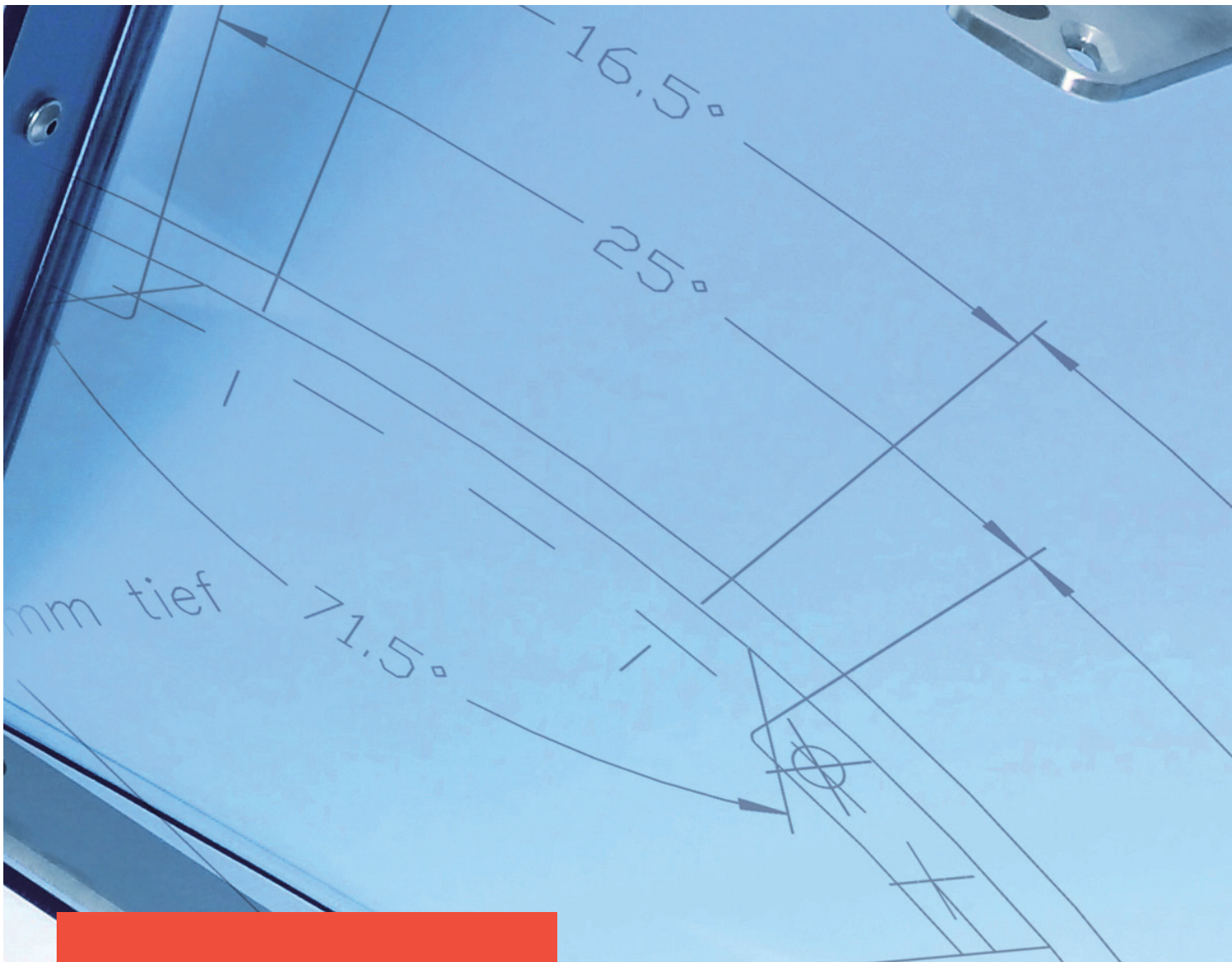



Content

A good choice – for sure 3

**A specialized material
that is reliable and durable** 4

PLEXIGLAS®

stands firm 5

provides insight 6

in mobile use 7

in public spaces 8

lights up rooms 9

**Products, applications
and properties** 10

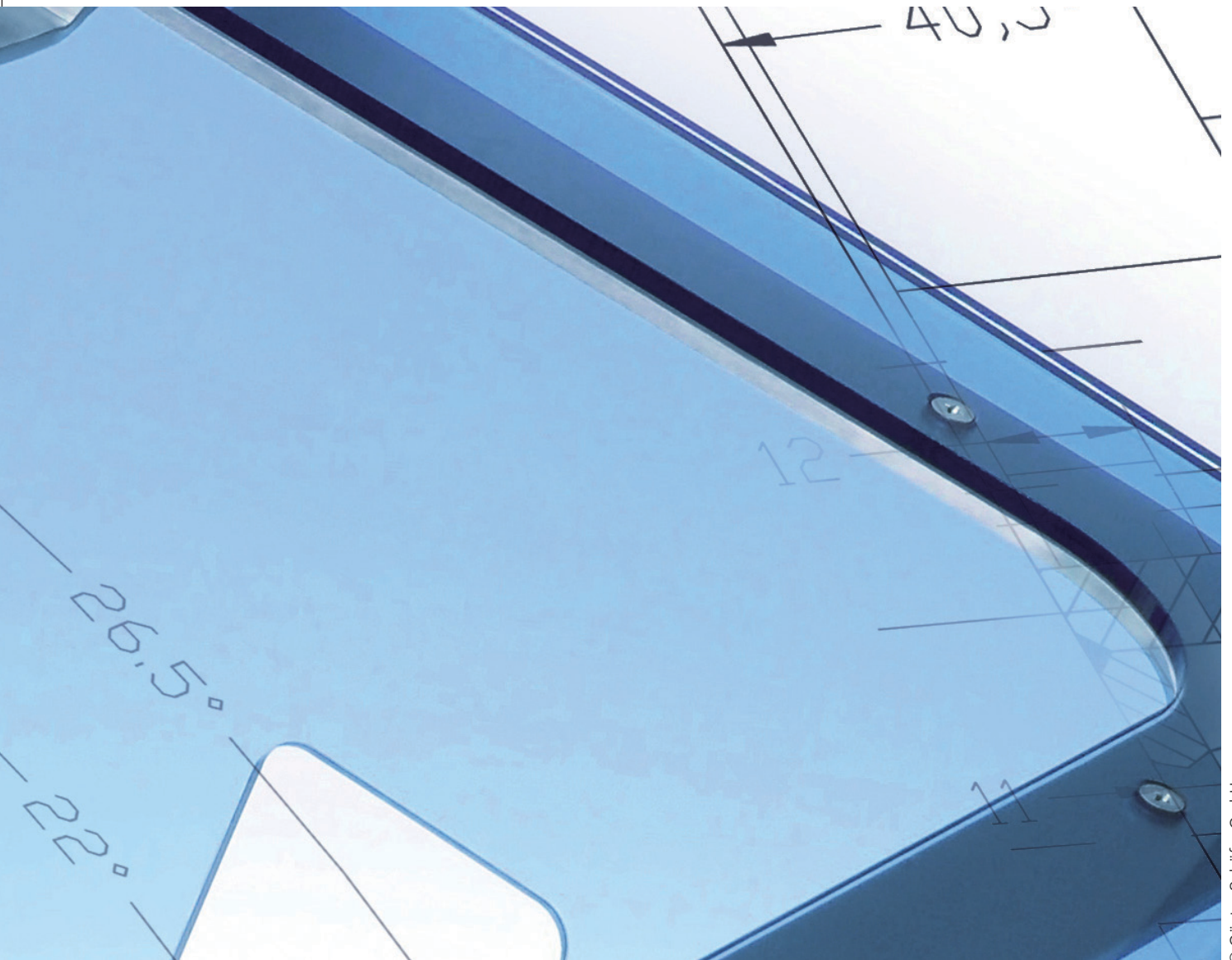

© Günter Schäfer GmbH

A good choice – for sure

Protection and safety are called for in many places – at machine workplaces, at bus stops, behind stadium barriers. Usually, it is people who require protection, but in some cases products do, too. Everyone would like to work without accidents, get home safely and enjoy their leisure time without harm. That applies to people all over the world.

Mechanical engineers, building contractors, vehicle manufacturers and shop builders all have to meet rising demands. Protective systems are gaining importance in global competition. These must provide permanent safety on the one hand and on the other, their appearance must reflect their purpose: to harm nothing and no one. In the best case, design serves safety, such as in public spaces. PLEXIGLAS® is the material of choice for such demanding applications.

We at Röhm are among the world's leading suppliers of PMMA and acrylic products, which were invented in 1933 by Dr. Otto Röhm and his team. The products we market under the PLEXIGLAS® brand (and under the ACRYLITE® brand in the Americas), as well as our know-how, are available everywhere, either directly via our global distribution network, via regional distributors or qualified fabricators.

Use our products to be on the safe side!



© HECKER® Kunststofftechnik Dortmund

A specialized material that is reliable and durable

PLEXIGLAS® is one of the world's highest-quality and most versatile plastics. It can be manufactured with many different functional properties and surfaces: highly light-transmitting, light-diffusing, light-focusing, sight-screening, heat-reflective, heat-shielding, heat-insulating, noise-reflecting, resistant to scratching and chemicals.

It is lighter in weight than glass but impact-resistant. This is an important criterion especially in applications whose foremost requirement is protection and safety. A further advantage is that the material can take rough treatment and is easy to machine. PLEXIGLAS® can be cold-curved or durably thermoformed to provide new, surprising effects and shapes that encourage attractive design. The low forming temperatures keep costs down. And, important not just for store fixtures: PLEXIGLAS® XT meets both EU food contact requirements and the FDA food contact regulations that apply in the USA.

PLEXIGLAS® remains clear, even many years later. There is no yellowing or embrittlement. Our clear-transparent PLEXIGLAS® solid sheets, multi-skin and corrugated sheets, blocks, tubes and rods come with a 30-year non-yellowing guarantee. Since PLEXIGLAS® remains virtually unchanged, it does not have to be replaced in the course of time, unlike other plastics. In addition, PLEXIGLAS® can be completely recycled, either by chemical conversion to its starting materials, or by direct reuse. These aspects, together with environmentally sound production, contribute to the material's sustainability.

To offer proof of this sustainability, we have performed an extensive life cycle assessment of the material from cradle to grave.

From production to recycling, the different environmental impacts of PLEXIGLAS®, including its greenhouse gas reduction effect due to the material's longevity, were determined and confirmed in this Life Cycle Assessment (LCA) in accordance with DIN ISO 14040ff.

PLEXIGLAS® also makes an essential contribution to reducing the burden on the environment during manufacture.

PLEXIGLAS® is also a good choice in terms of safety. It burns with almost no smoke, forms no acutely toxic smoke gases and can be easily extinguished with water.

PLEXIGLAS® products come in many forms, as solid, multi-skin and corrugated sheets, blocks, tubes and rods.

PLEXIGLAS® offers convincing toughness, ease of fabrication, weather resistance, brilliance and colorfastness. It provides reliable protection and safety both indoors and outdoors. At the same time, it enables fabricators, mechanical engineers, vehicle manufactures and shop builders to fulfill even the most unusual design wishes.

PLEXIGLAS® stands firm



© HECKER® Kunststofftechnik Dortmund

Machines are meant to work properly and keep on producing. Every interruption costs time and money. One of the main aims of mechanical engineers is to protect the machine from external influences and at the same time save its operators from being injured. Everyday operation calls for hard-wearing material that offers a clear view of the machine workings at all times.

Highly transparent PLEXIGLAS® unites all these requirements, for example in protective hoods or industrial clean room glazing. Both offer a clear view as well as all-round protection and resistance. The robust material withstands knocks, scratches and chemicals almost without a trace. The clear view of the machine workings is retained for many years because the material is insensitive to light and protects against UV radiation. This helps machines make a good impression even on factory tours, while complying with safety regulations.

Users of food and beverage dispensers want to see what they are getting for their money. Operators want their machines to withstand kicks or blows. Impact-resistant PLEXIGLAS® Resist satisfies both requirements. Yet another reason to trust in this material.

PLEXIGLAS® XT

PLEXIGLAS® GS

PLEXIGLAS® Resist



© HECKER® Kunststofftechnik Dortmund

PLEXIGLAS® provides insight

Being open for innovations is among the success factors in every industry. A new material is to be profitably used for structural components? No problem with PLEXIGLAS®.

It is not only transparent, but also easy to handle. Precision drilling, routing and laser cutting pose no problem whatsoever. What's more, the plastic is so easy to form that it offers almost unlimited freedom of design to constructors, unlike other materials.

Its properties even make it possible to cut extremely complex lines into the material, like those used in fluid technology, by means of a router.

Liquid or gaseous substances wind their way through channels that are precisely routed into transparent PLEXIGLAS® sheets. The brilliant appearance of PLEXIGLAS® enables viewers to observe the process in every detail.

A multitude of options, fewer errors, greater efficiency – PLEXIGLAS® offers crucial benefits.

PLEXIGLAS® XT

PLEXIGLAS® GS

PLEXIGLAS® Resist

PLEXIGLAS® Optical



Driving a forklift truck, an excavator or sizing up the 18th hole on a golf course: outdoor activities call for maximum protection from all winds and weathers. They also call for maximum safety. It is no small feat to fulfill all these demands. The suitable material helps manufacturers of special-purpose vehicles to find the right solution.

PLEXIGLAS® weighs only half as much as glass, for example, but offers 11 times its impact strength. This is a dual benefit. Firstly, the weight saving increases transport capacity – funicular rail cars can transport more passengers, forklifts more goods.

PLEXIGLAS®
in mobile use

PLEXIGLAS® XT

PLEXIGLAS® GS

PLEXIGLAS® Resist

PLEXIGLAS® in public spaces



Thermal processes are ideal for forming glazing to the required shape. PLEXIGLAS® can also be cold-curved. That makes it possible to realize individual design ideas in public spaces at no great expense. From curved roofs for bus stops to barrel vaults above a hotel entrance, a welcoming exterior makes for a pleasant atmosphere. Experience also shows that attractive structures are less likely to be vandalized.

Seen in this light, there are no obstacles to mobile leisure activities or to safe work and travel. Winds, weathers and vandalism stand little chance of inflicting damage.



PLEXIGLAS® XT

PLEXIGLAS® Resist

PLEXIGLAS® Optical

PLEXIGLAS® Textures

PLEXIGLAS® lights up rooms

Whether you find them on the sales floor, at the fire department or in workshop halls, sectional doors ought to let in light. They should also be as easy to open as possible. And all of these demands showcase the key strengths of PLEXIGLAS®: it is non-breakable, lightweight, and lets in even more light than glass.

Because it is so lightweight, PLEXIGLAS® is the ideal match for electric motors, where it reduces energy consumption – and that ultimately translates into more cash. The material is also weather resistant, guaranteeing years of bright light – PLEXIGLAS® really does come with a transparency guarantee, ensuring that it will show no yellowing during the warranty period. PLEXIGLAS® Optical HC has all of this plus it is insensitive against sand and dirt.

Suitable, in other words, for large overhead doors that flood a room with light.

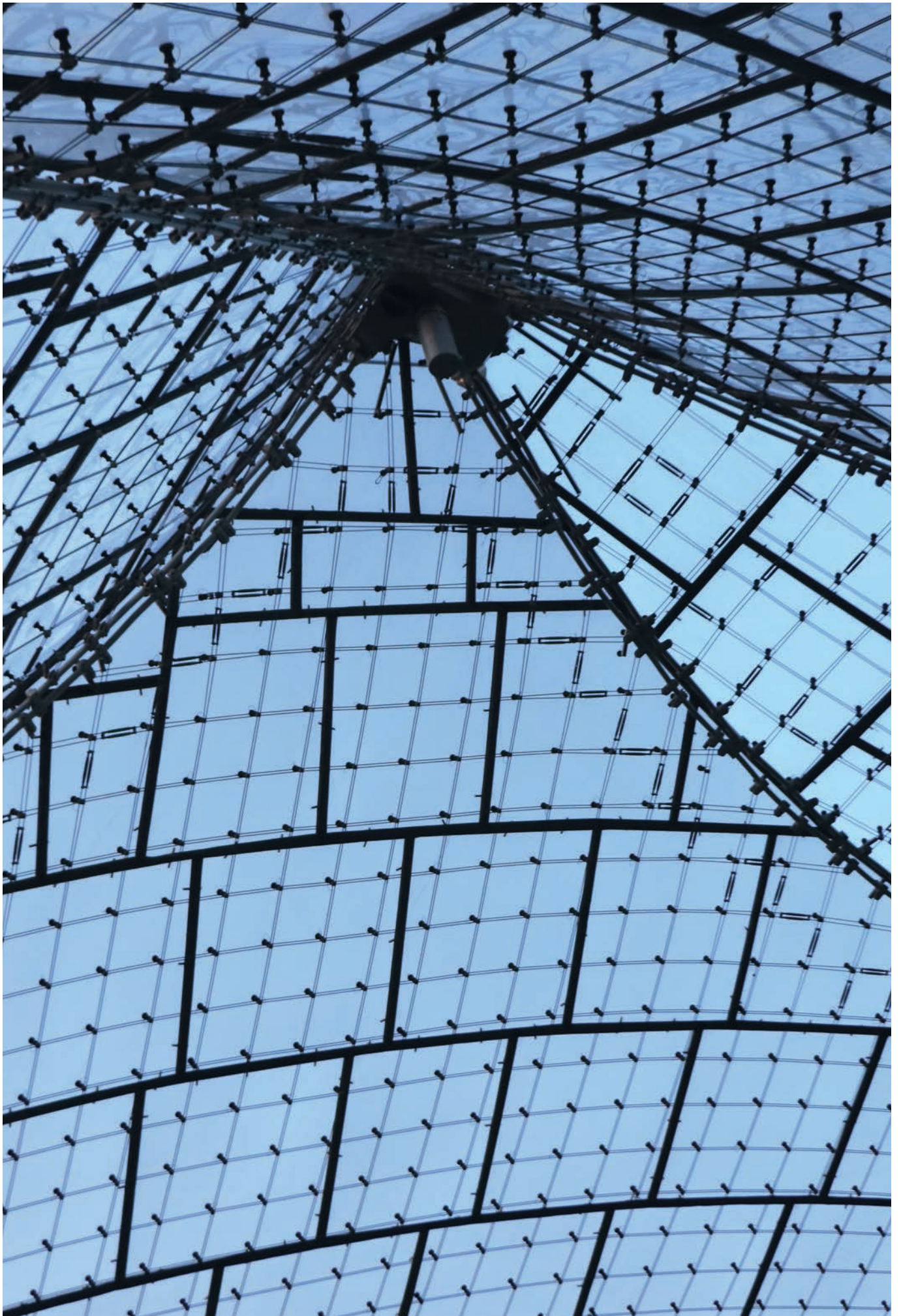

Products, applications and properties

| Products | Housing for machines | Industrial parts | Vehicle glazing | Structural glazing outdoors |
|-----------------------|----------------------|------------------|-----------------|-----------------------------|
| PLEXIGLAS® GS/XT | • | • | • | • |
| PLEXIGLAS® Resist | • | • | • | • |
| PLEXIGLAS® Optical HC | • | • | • | • |



SUSTAINABILITY

The Sustainable Development Goals (SDG), adopted by the United Nations in 2016, all have one goal: By 2030, all inhabitants of planet Earth should be able to live in dignity.

To this end, the United Nations has formulated 17 goals to support global sustainability efforts. The SDGs are our compass in aligning our sustainability-strategy, creating innovations and identifying new business opportunities and take advantage of them.

Products and solutions from Röhms make a measurable contribution to achieving these goals. This is how we assume responsibility.



Röhms GmbH
Acrylic Products

Riedbahnstraße 70
64331 Weiterstadt
Germany

www.plexiglas.de
www.roehm.com

® = registered trademark

PLEXIGLAS is a registered trademark of Röhms GmbH, Darmstadt, Germany.

Certified to DIN EN ISO 9001 (Quality) and DIN EN ISO 14001 (Environment)

This information and all further technical advice is based on our present knowledge and experience. However, it implies no liability or other legal responsibility on our part, including with regard to existing third party intellectual property rights, especially patent rights. In particular, no warranty, whether express or implied, or guarantee of product properties in the legal sense is intended or implied. We reserve the right to make any changes according to technological progress or further developments. The customer is not released from the obligation to conduct careful inspection and testing of incoming goods. Performance of the product described herein should be verified by testing, which should be carried out only by qualified experts in the sole responsibility of a customer. Reference to trade names used by other companies is neither a recommendation, nor does it imply that similar products could not be used.